

PORCH-LIFT®
VERTICAL PLATFORM LIFT

Planning Guide

for PL-S Standard Model in a Hoistway
for Architects and Lift Contractors

May 5, 2008

ThyssenKrupp Access



ThyssenKrupp

Introduction

This Planning Guide is designed to assist architects, contractors, building owners and lift contractors in planning for a Porch-Lift® vertical platform lift that meets the requirements of ASME A18.1.

We strongly recommend you contact the codes authority having jurisdiction in the area(s) where the wheelchair lift will be installed. Become familiar with all requirements governing the installation and use of wheelchair lifts. It is extremely important for you to know and adhere to all regulations concerning installation and use of wheelchair lifts.

IMPORTANT NOTICE:

This Planning Guide provides nominal dimensions and specifications useful for INITIAL planning of a wheelchair lift project. BEFORE beginning actual construction, be sure to receive application drawings customized with specifications and dimensions for your specific project. Call 1-800-829-9760 to find a dealer in your area.

Wheelchair lift configurations and dimensions are in accordance with our interpretation of the standards set forth by ASME A18.1. Please consult ThyssenKrupp Access or an authorized dealer in your area for more specific information pertaining to your project, including any deviation between referenced standards and those of any local codes or laws. Always contact local codes authorities for any variation to standards.

The dimensions and specifications in this Planning Guide are subject to constant change (without notice) due to product enhancements and continually evolving codes and product applications.

Contents

| | |
|--|-------|
| Porch-Lift overview | 3 |
| Drive systems | 4 |
| Model heights | 4 |
| Power requirements..... | 4 |
| Hoistway layouts | 5-6 |
| Door and gate details | 7-9 |
| Mounting details | 10 |
| Static anchoring load calculations | 11 |
| Features | 12-13 |
| 3-Part specifications..... | 14-15 |

Porch-Lift overview

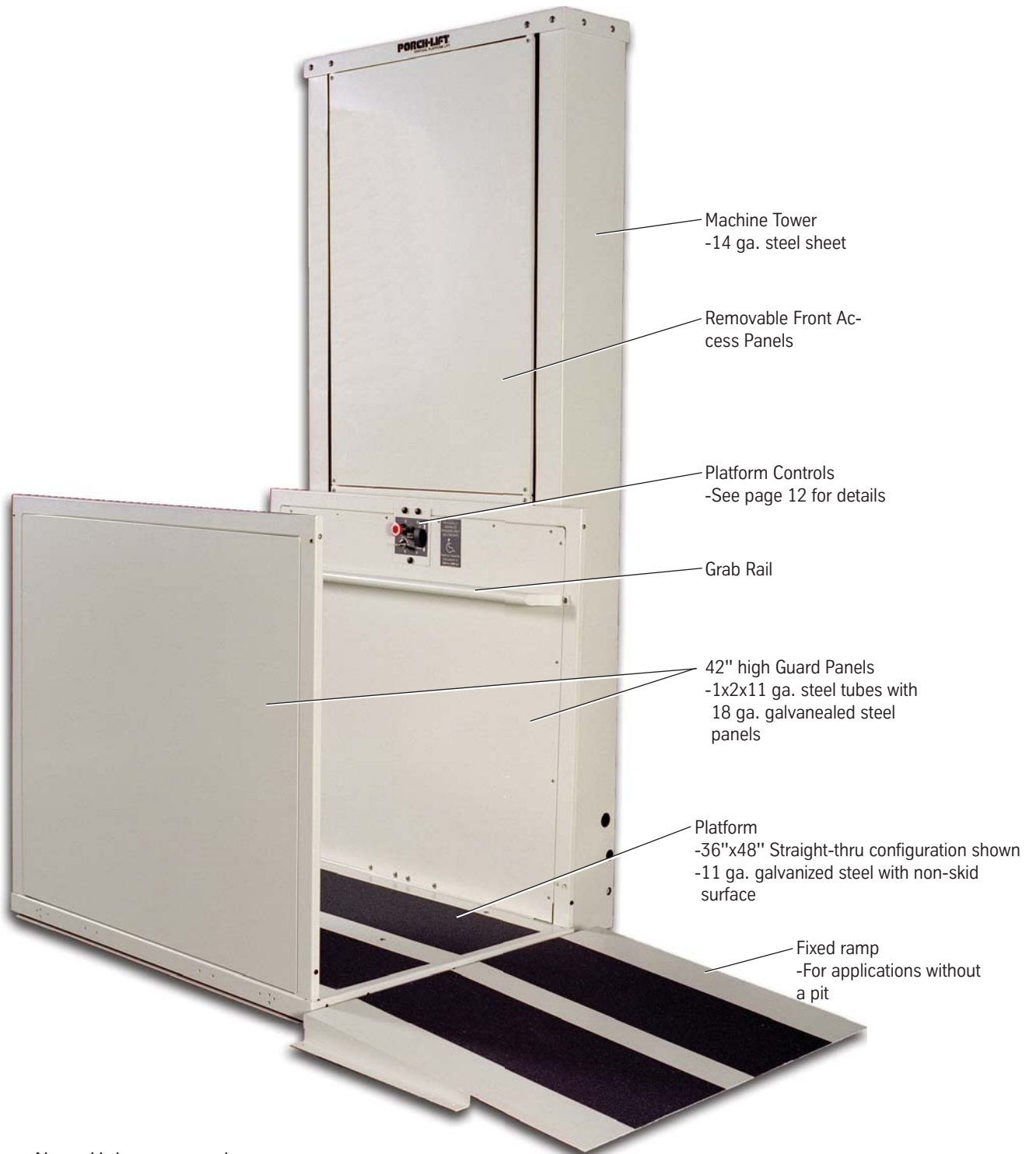

Note: Hoistway not shown.

| Drive Systems | A/C Powered Ballscrew Drive | Battery Powered Ballscrew Drive | Battery Powered Hydraulic Drive |
|---------------------|---|--|---|
| Motor | ½ hp motor 120 V 60 Hz Reversible | ½ hp motor 24 VDC Reversible | ¾ hp pump motor 24 VDC .83 gpm @ 1500 psi pump w/ relief switch |
| Batteries | N/A | (2) 12 V, 33 AH, sealed, no maintenance batteries with 24 V, 1.7 amp Smart Charge™ battery charger | (2) 12 V, 33 AH, sealed no maintenance batteries with 24 V, 3.3 amp Smart Charge™ battery charger |
| Brake | Electromechanical | Electromechanical | Hydraulic |
| Safety | Ballscrew safety nut Manual Lowering Device | Ballscrew safety nut Manual Lowering Device | Manual Emerg Lowering Relief Valve Broken rope safety device |
| Speed w/ rated load | 9-12 feet/minute | 9-12 feet/minute | 18-21 feet/minute |
| Notes | Single V-belt drive system with monitoring switches | | 1:2 Roped hydraulic single stage 42mm cylinder with line rupture valve Two 3/8" diameter aircraft ropes |

General Equipment on all drive systems:

- 750 lbs. Rated load
- Platform safety pan
- 2 or 3 Landings
- 2 years drive train and 1 year limited warranty on all other component parts
- Constant pressure, low voltage controls; paddle switch with key operation and emergency stop with alarm
- 42" High guard panels on platform with grab rail
- Relay logic motor controls
- ETL & UL Listed when lifting height ≤ 144"
- Final limit switches
- 36"x48", 36"x56" or 36"x60" Platform with non-skid surface

Model heights

The model height required for a particular application is determined by the "lifting height", which is the vertical distance between the upper landing and the bottom of the lift. (See illustrations to the right.)

If the lift is not mounted in a pit, a stationary ramp is required outside of the hoistway. A fixed ramp is provided as standard equipment. (See details on page 13.)

| MODEL | MAXIMUM LIFTING HEIGHT | MACHINE TOWER HEIGHT |
|-----------|------------------------|----------------------|
| PL-S 36 | 3'-3" | 59 ¼" |
| PL-S 50 | 4'-5" | 73 ¼" |
| PL-S 72 | 6'-3" | 95 ¼" |
| PL-S 96 | 8'-3" | 119 ¼" |
| PL-S 120 | 10'-3" | 143 ¼" |
| PL-S 144 | 12'-3" | 167 ¼" |
| PL-S 168* | 14'-3" | 191 ¼" |

* Local or state variance required if travel of platform exceeds 12'-0".

Machine tower is 38 ½" wide, the tower cap is 39" wide.

Lift Height is measured from base of unit

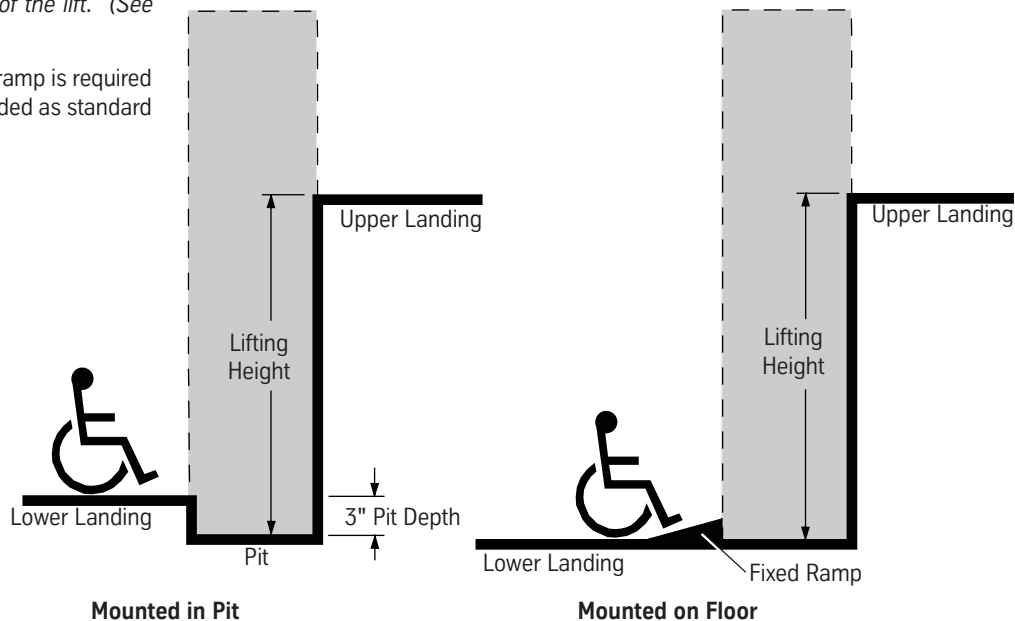

Power requirements

115 VAC, single phase, 20 amp, 60 Hz power circuit required to be supplied by others.

Note: Battery powered lifts must be connected to the AC power source to charge the batteries.

Hoistway layout Straight-thru platform

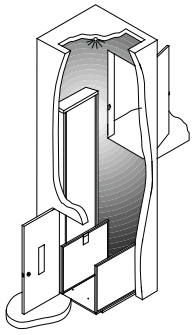

3 Sizes: 36" x 48" (standard)
36" x 56"
36" x 60"

Available with 2 or 3 stops.

6'-8" minimum above top landing floor required for overhead clearance.

* Doors and gates are to be centered on the platform opening. See door and gate details for construction openings.

Note: Overall dimensions and running clearances conform to ASME-A18.1. Dimensions are to finished walls.

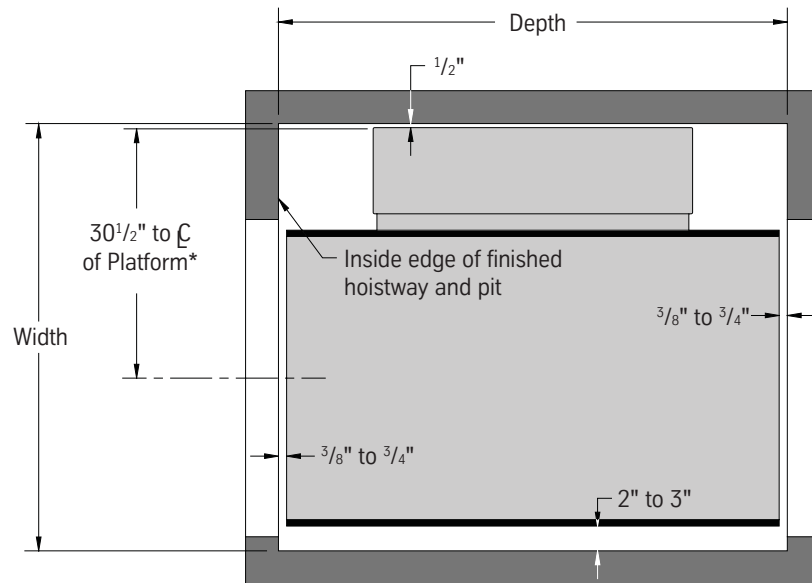

| Platform Size | Hoistway dimensions | |
|---------------|---------------------|-------|
| | Width | Depth |
| 36" x 48" | 51 | |
| | | |
| | | |

Hoistway layout 90° Exit platform

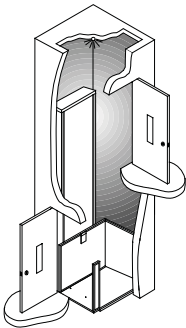

4 Sizes: 36" x 48" (standard)
36" x 56"
36" x 60"
42" x 60" – clear

Available with 2 or 3 stops. (On 3 stop lifts, the top landing door or gate must be on the wide side of the platform.)

6'-8" minimum above top landing floor required for overhead clearance.

* Doors and gates are to be centered on the platform opening. See door and gate details for construction openings.

Note: Overall dimensions and running clearances conform to ASME-A18.1. Dimensions are to finished walls.

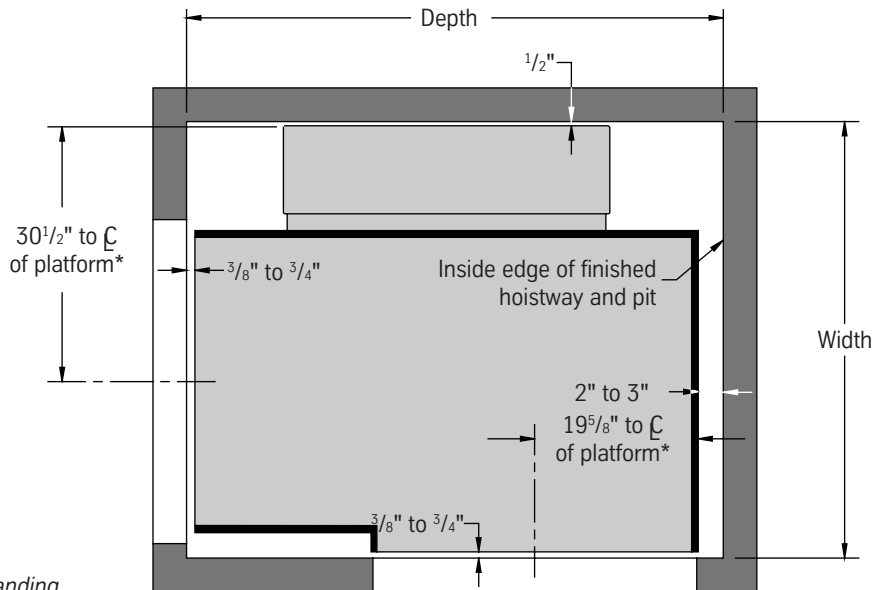

Left hand configuration shown, right hand opposite.

| Platform Size | Hoistway dimensions | |
|---------------|--|--|
| | Width | Depth |
| 36" x 48" | 51 ³ / ₈ " to 51 ³ / ₄ " | 50 ³ / ₈ " to 51 ³ / ₄ " |
| 36" x 56" | 51 ³ / ₈ " to 51 ³ / ₄ " | 58 ³ / ₈ " to 59 ³ / ₄ " |
| 36" x 60" | 51 ³ / ₈ " to 51 ³ / ₄ " | 62 ³ / ₈ " to 63 ³ / ₄ " |
| 42" x 60" | 59 ³ / ₈ " to 59 ³ / ₄ " | 63 ³ / ₈ " to 64 ³ / ₄ " |

Hoistway layout
Enter/exit same side platform

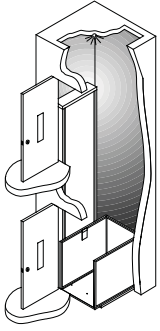

3 Sizes: 36" x 48" (standard)
 36" x 56"
 36" x 60"

Lifting height must be a minimum of 8'-0".

Available with 2 stops only.

6'-8" minimum above top landing floor required for overhead clearance.

* *Doors and gates are to be centered on the platform opening. See door and gate details for construction openings.*

Note: Overall dimensions and running clearances conform to ASME-A18.1. Dimensions are to finished walls.

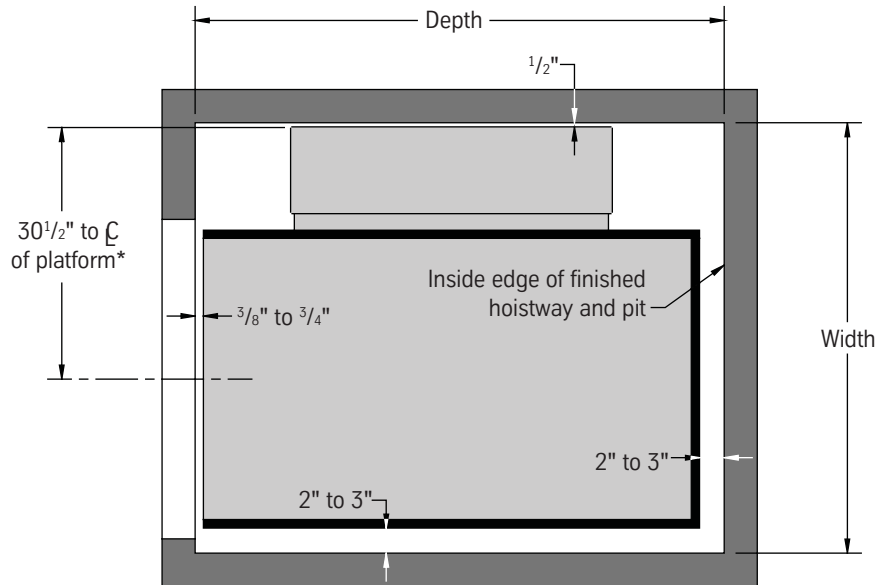

Left hand configuration shown, right hand opposite.

| Platform Size | Hoistway dimensions | |
|---------------|---------------------|--|
| | Width | Depth |
| 36" x 48" | 51" to 52" | 50 ³ / ₈ " to 51 ³ / ₄ " |
| 36" x 56" | 51" to 52" | 58 ³ / ₈ " to 59 ³ / ₄ " |
| 36" x 60" | 51" to 52" | 62 ³ / ₈ " to 63 ³ / ₄ " |

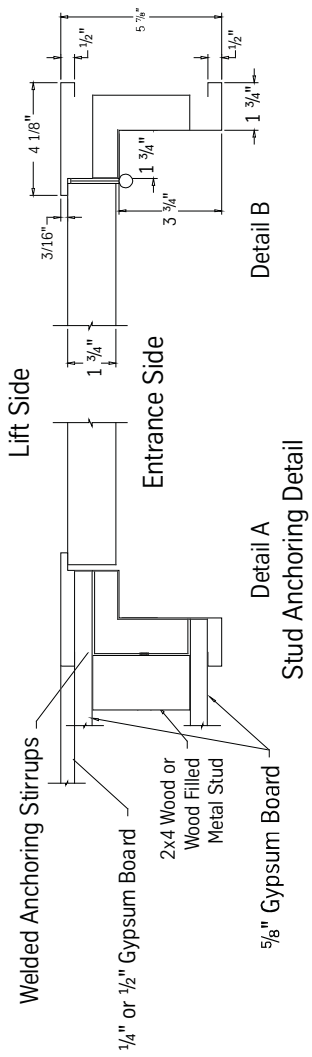
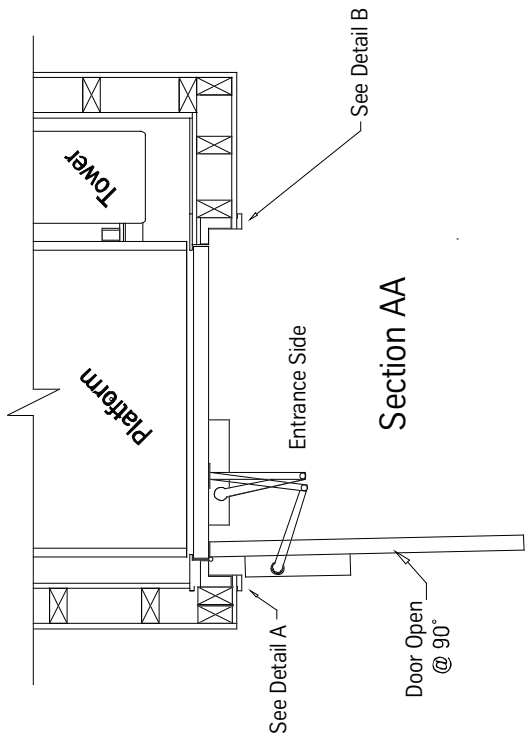

Masonry Anchor

used in masonry applications only

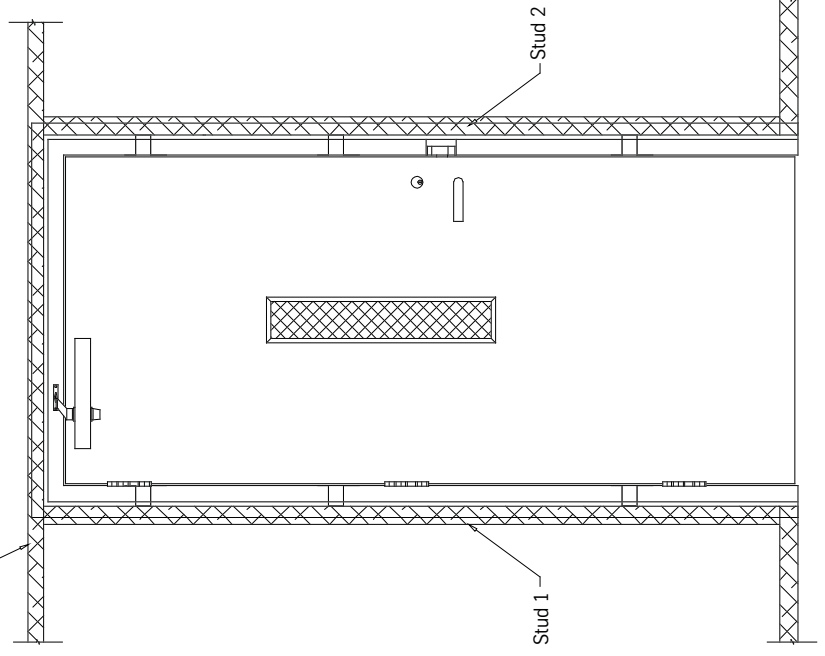
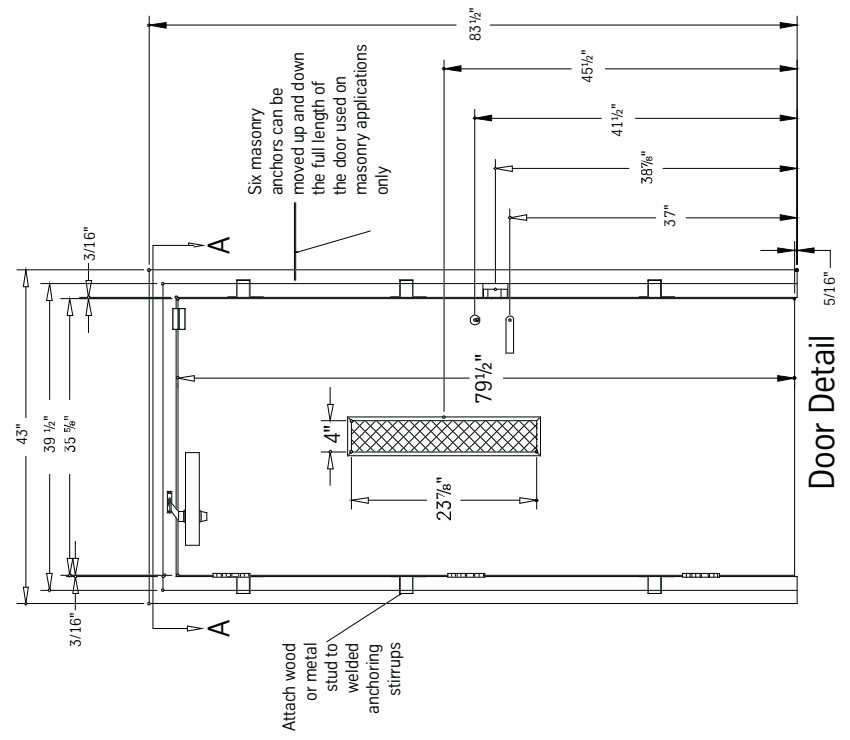

Installation Detail

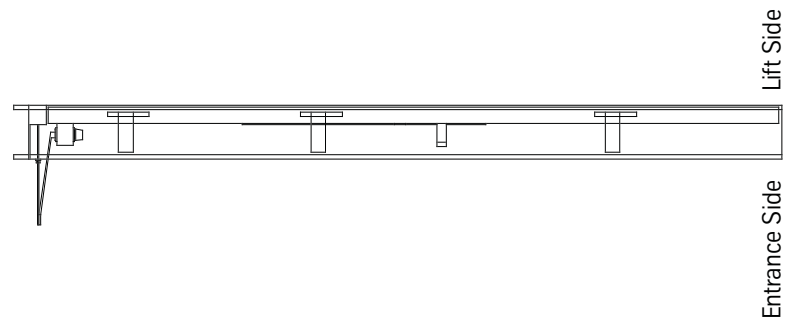

Side View

Doors

Fire rated door with VDR™ interlock

- 1½ hour 'B' label fire rating.
- Constructed of steel sheet metal, primed for painting at jobsite.
- Hoistway side of door and frame is mounted flush with the hoistway wall.
- U.L. Listed mechanical interlock included inside door frame.
- Call/send control can be mounted in the door frame adjacent to the door pull (optional).
- 4' wide 6'8" tall door available for 90° units
- 3' wide 6'8" tall door standard

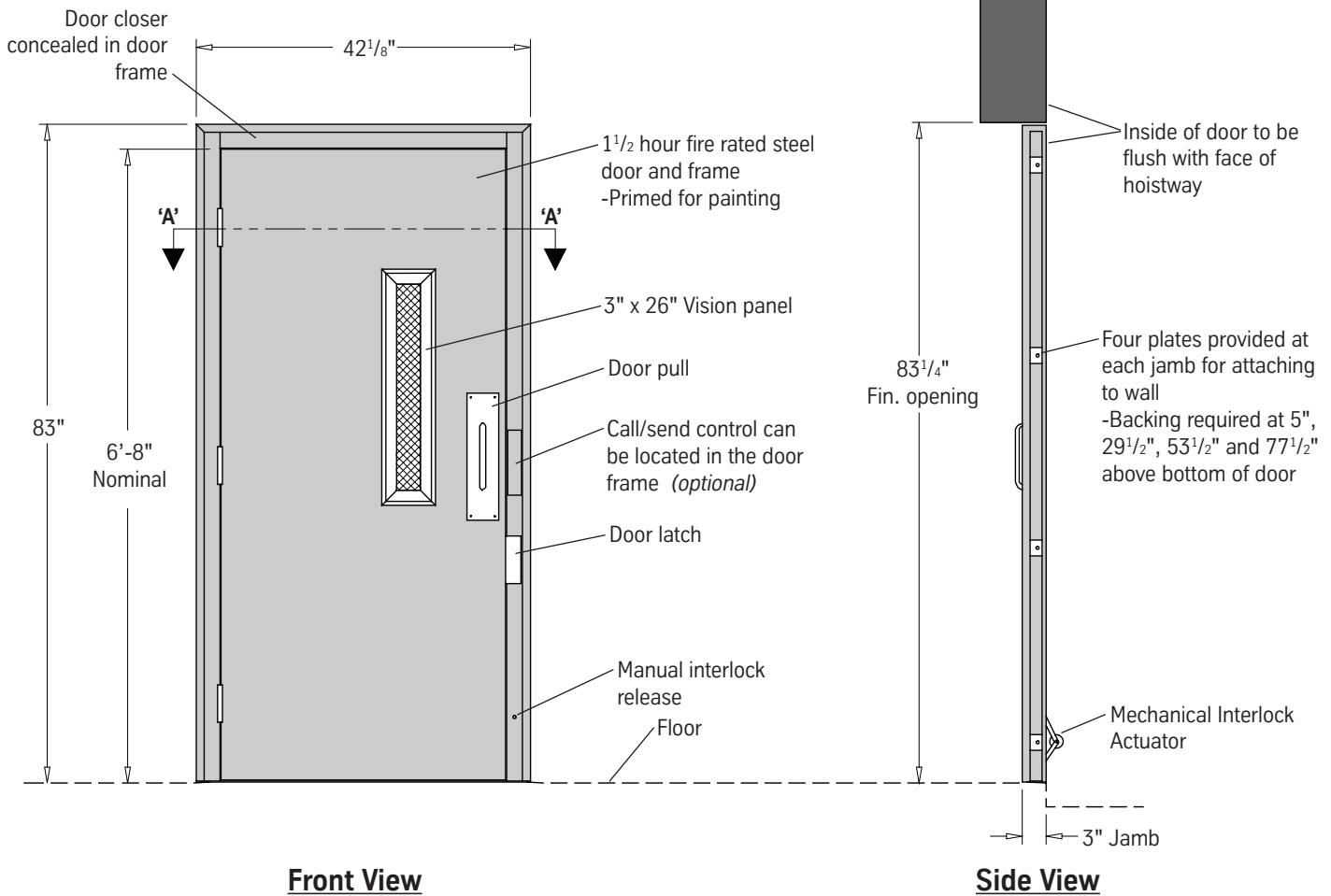
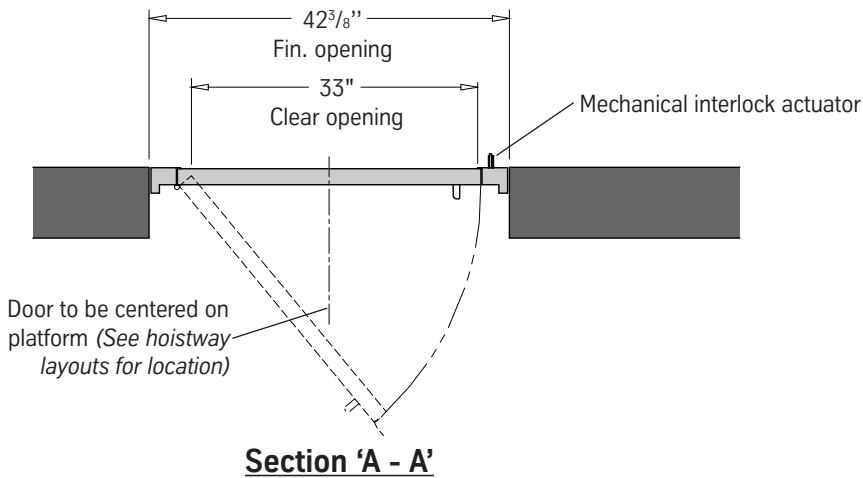

Top landing gate with VDR™ interlock

- Hoistway side of gate and frame is mounted flush with the hoistway wall.
- UL listed mechanical interlock included inside door frame.
- Call/send control can be mounted in the gate frame adjacent to the door pull (optional).
- An extra wide 43" and 49" gate can be provided for use with a 90° exit platform.

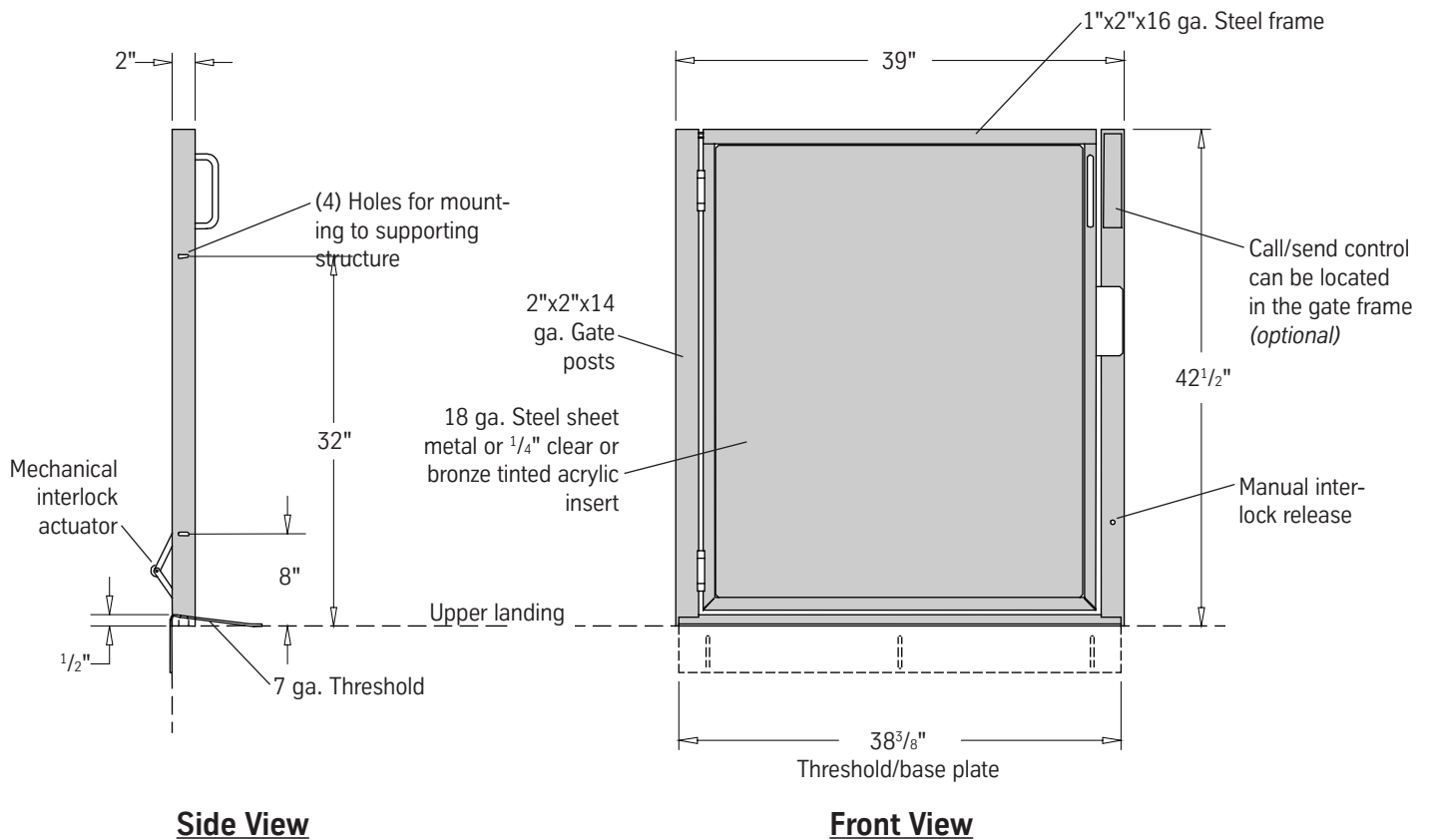
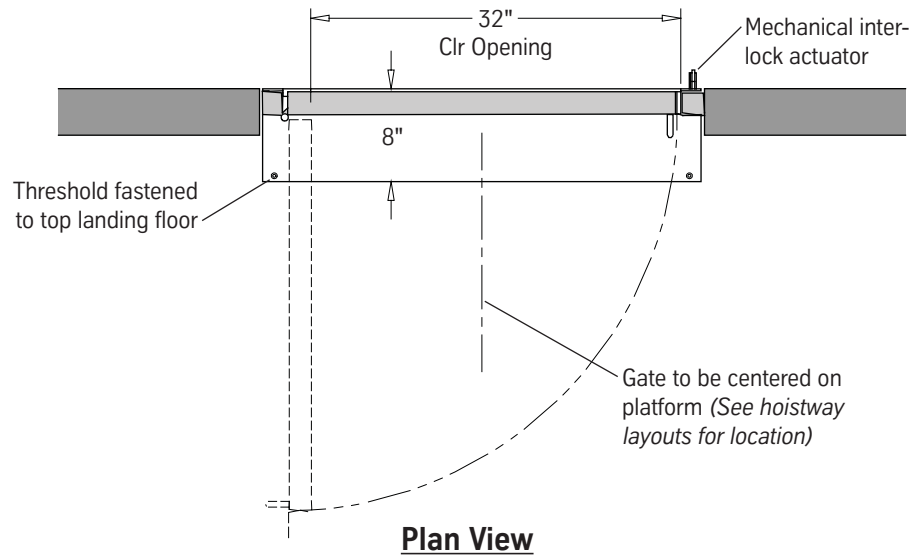

Mounting details

Floor anchor detail

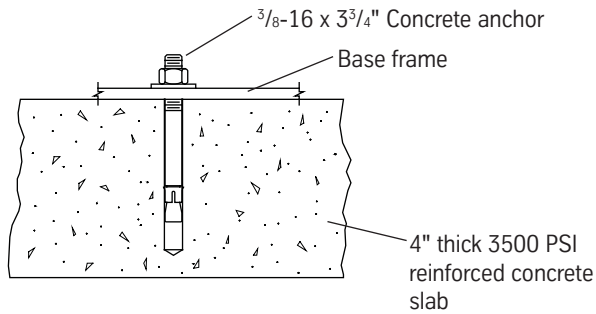

Base frame anchor locations

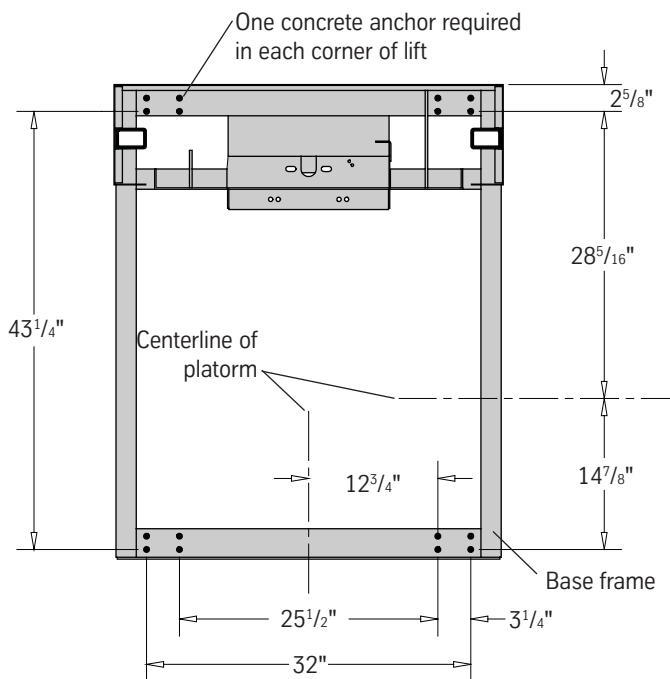

Machine tower anchor locations

If the lifting height of the unit is over 75", the machine tower must be anchored to a supporting structure at two points within 12" of the top of the tower.

Pull out force at top anchor*:

| Model | LBF |
|----------|-----|
| PL-S 96 | 235 |
| PL-S 120 | 191 |
| PL-S 144 | 161 |
| PL-S 168 | 139 |

* Top support located within 12" of the top of the machine tower. Does not include safety factor.

Static anchoring load calculations

Floor loading of PL-S with ballscrew drive

| Ballscrew Drive Lift Model | Tower Weight T lbs | Car Weight C lbs | Payload Weight P lbs | Rear Support* R1 lbs | Front Support* R2 lbs | Top Support** R3 lbs | Minimum Support Hgt H inches | Uniform Floor Loading*** Footprint = 344 in. ² psi |
|----------------------------|--------------------|------------------|----------------------|----------------------|-----------------------|----------------------|------------------------------|---|
| PL-S 36 | 386 | 390 | 750 | 809 | 716 | | | 4.43 |
| PL-S 50 | 424 | 390 | 750 | 845 | 719 | | | 4.54 |
| PL-S 72 | 483 | 390 | 750 | 900 | 723 | | | 4.72 |
| PL-S 96 | 548 | 390 | 750 | 961 | 727 | 524 | 75 | 4.91 |
| PL-S 120 | 613 | 390 | 750 | 1021 | 732 | 397 | 99 | 5.10 |
| PL-S 144 | 678 | 390 | 750 | 1082 | 736 | 320 | 123 | 5.28 |
| PL-S 168 | 743 | 390 | 750 | 1142 | 741 | 267 | 147 | 5.47 |

Floor loading of PL-S with hydraulic drive

| Hydraulic Drive Lift Model | Tower Weight T lbs | Car Weight C lbs | Payload Weight P lbs | Rear Support* R1 lbs | Front Support* R2 lbs | Top Support** R3 lbs | Minimum Support Hgt H inches | Uniform Floor Loading*** Footprint = 344 in. ² psi |
|----------------------------|--------------------|------------------|----------------------|----------------------|-----------------------|----------------------|------------------------------|---|
| PL-S 50 | 547 | 390 | 750 | 959 | 727 | | | 4.90 |
| PL-S 72 | 641 | 390 | 750 | 1047 | 734 | | | 5.18 |
| PL-S 96 | 743 | 390 | 750 | 1142 | 741 | 524 | 75 | 5.47 |
| PL-S 120 | 846 | 390 | 750 | 1237 | 748 | 397 | 99 | 5.77 |
| PL-S 144 | 948 | 390 | 750 | 1333 | 755 | 320 | 123 | 6.07 |
| PL-S 168 | 1051 | 390 | 750 | 1428 | 762 | 267 | 147 | 6.37 |

Notes:

- * Assume point loads at front and rear of machine tower.
- * Divide total load per quantity of anchors.
- * Loads are in compression.
- ** Loads are in tension.
- ** Minimum safety factor of 4 recommended.
- *** Applicable only with level pad with no shims.

Calculations do not include forces due to wind, seismic loading or snow loading, and do not include forces due to acceleration.

Increasing support height (H) decreases R3 anchor load. Consult factory for details.

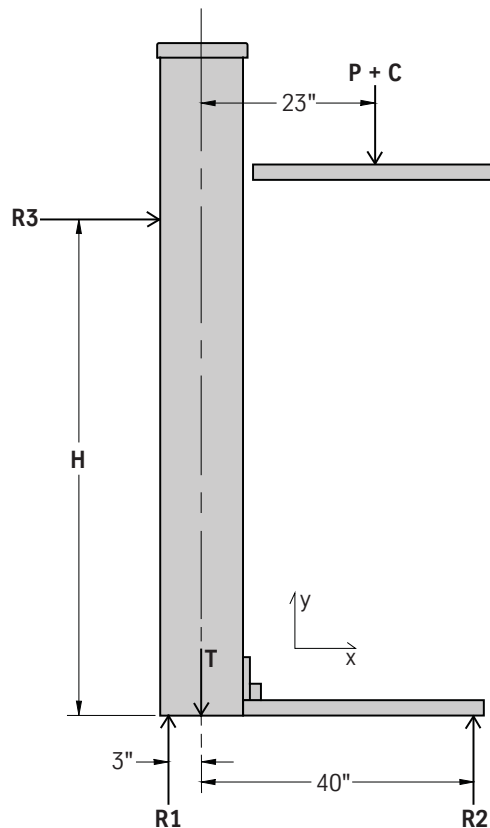

Features

Platform controls



Used to control the platform while riding on the platform.

- Constant pressure up and down paddle switch.
- Key switch with key removable in "off" position only.
- Emergency stop switch (push to 'stop', pull to 'run' operation) and signalling device. *Signalling device is an alarm that sounds when the emergency stop is activated.*
- Illuminated alarm button to sound the alarm at anytime.

Call/send controls

-Shown with optional Emergency Stop Switch and Surface Mount Box



Used to control the platform from a landing.

- Constant pressure up and down paddle switch.
- Can be provided with or without an emergency stop switch and signalling device. *Signalling device is an alarm that sounds when the emergency stop is activated.*
- Key switch with key removable in "off" position only.
- Shipped with a water tight black plastic box that can be surface mounted to a wall or can be flush mounted by recessing an electrical double gang box into the wall.
- Conduit and wires between control and the lift are to be provided by others.
- The call/send control can also be integrated into gates or doors.

Remote emergency lowering switch (optional on hydraulic drive only)



Used to lower the platform in the event of an emergency.

- To be located at the lower landing within sight of the platform.
- Constant pressure key switch; turn key to lower platform.
- Shipped with a watertight metal box that can be surface mounted to a wall or can be flush mounted by recessing an electrical gang box into the wall.
- All safety devices are disabled during operation of switch.
- Conduit and wires between control and the lift are to be provided by others.
- This is in addition to the standard manual emergency lowering relief valve.

Pit switch (optional)



Used to disable all controls while maintenance is being performed underneath the platform.

- Mounted to bottom of machine tower within arms reach of the lower landing door.
- Push to 'stop', pull to 'run' operation.

Grab rail



Used to assist a wheelchair user in maneuvering on the platform.

- Mounted on platform guard panel on machine tower side.
- Located 33" above platform floor.

Fixed access ramp



Used when the lift is mounted to the lower landing floor (vs. mounting inside a pit.)

- 1:12 slope.
- 43" wide x 31½" deep.
- Non-skid surface.

Note: Lower landing door must be blocked up 3" to accommodate the fixed access ramp.

AutoOpener™ (optional)



Automatically opens gate or door when platform stops at the landing.

- Mounts to wall near top of gate/door on the hinge side. Backing is required by contractor.
- Automatically reverses when an obstruction is encountered.
- If platform is already at the landing, gate/door can be opened by pressing call/send switch.
- Requires 115 VAC outlet near the top of the gate/door on the hinge side at each landing.

Battery disconnect (optional on hydraulic drive only)

Used to disable lift without disconnecting the batteries.

- Located inside the machine tower.

Telephone jack (optional)

Used to provide telephone service for the user in event of an emergency.

- Located near the platform controls.
- Telephone or ADA compliant equipment optional.

Optional colors

- The standard color for all equipment is ivory.
- Optional colors of sable brown, pearl gray or taupe are available.
- Special order colors (select from 180 RAL colors) are available at a premium. Download color chart at www.accessind.com/ral

SECTION 14420 WHEELCHAIR LIFTS

PART 1 GENERAL

1.01 SUMMARY

A. A vertical platform (wheelchair) lifting device, manufactured by ThyssenKrupp Access, designed to provide access to or within a building for mobility impaired persons. Lift consists of machine tower and lifting platform selected and dimensioned to provide adequate lifting height to suit building access requirements indoors and out.

1.02 REFERENCES

A. Lift shall be designed, manufactured and installed in accordance with the following standards:

1. American National Standards Institute (ANSI).
2. American Society of Mechanical Engineers (ASME).
3. ADA Accessibility Guidelines (ADAAG).
4. Underwriters Laboratories (UL).
5. International Building Code (IBC).
6. National Electrical Code (NEC).
7. American Society for Testing Materials (ASTM).
8. American Welding Society (AWS).

1.03 SYSTEM DESCRIPTION

A. Drive: (specify:)

1. AC powered ballscrew drive; 1/2 hp, 120 V, 60Hz, instant reversing motor.
2. Battery powered ballscrew drive; 1/2 hp, VDC, instant reversing motor with two 12 V, 33 AH, sealed no maintenance batteries with 24V 1.7 amp "smart charge" battery charger.
3. Battery powered 1:2 roped hydraulic drive; 3/4 hp, 24 VDC pump motor with two 12 V, 33 AH, sealed no maintenance batteries with 24 V 3.3 amp "smart charge" battery charger.

B. Number of Stops: (specify:) 2 stops or 3 stops.

C. Platform Configuration: (specify:) straight-thru, 90° exit or enter/exit same side.

D. Maximum Travel: (specify:) 39", 53", 75", 99", 123", 147" or 171".

E. Rated Load: 750 lbs. with minimum safety factor of 5X.

F. Rated Speed: 9-12 fpm (ballscrew drive) or 18-21 fpm (hydraulic drive) with rated load.

G. Platform Size: (specify:) 36"x48", 36"x56" or 36"x48" with 42" high guard panels.

H. Main Power Supply Wiring: Electrical contractor shall provide 115 VAC, single phase, 20 amp, 60 Hz power circuit.

J. Operating Features:

1. Platform Controls: Directional paddle switch, on/off key switch, emergency stop switch with alarm and illuminated alarm button.
2. Landing Controls: Directional paddle switch and on/off key switch (specify options:) emergency stop switch with alarm, mounted inside gate/door frames.
3. Constant pressure operation.
4. Grounded electrical system with upper, lower and final limit switches and 24 V operating controls.
5. Platform underpanel equipped with obstruction sensors.
6. Ramp with incline of 1:12 (required if lift is not installed in a pit).
7. Non-slip surface on platform floor and ramp.
8. Grab rail on platform.
9. Manual lowering device.

10. Remote emergency lowering switch (optional on hydraulic drive).

11. Integral ballscrew safety device and electromechanical brake (ballscrew drive).

12. Broken rope safety device and flow control valve (hydraulic drive).

13. Pit switch (where required by code).

14. Telephone jack on platform (optional).

15. Upper Landing Gate/Door: (specify:)

- a. 42" high, self-closing gate with VDR™ mechanical interlock and (specify:) steel sheet or acrylic insert panel.
- b. 6'-8" self closing, flush mount, 1-1/2 hour fire rated door with VDR™ mechanical interlock and 3"x26" glass vision panel.

16. Lower/Middle Landing Door: (specify:)

- a. 6'-8" self closing, flush mount, 1-1/2 hour fire rated door with VDR™ mechanical interlock and 3"x26" glass vision panel.

17. Automatic Gate/Door opener (optional).

1.04 QUALITY ASSURANCE

A. Manufacturer: Provide wheelchair lift manufactured by a firm with a minimum of 25 years experience in fabrication of wheelchair lifts equivalent to those specified.

B. All designs, clearances, workmanship and material, unless specifically excepted, shall be in accordance with all codes having legal jurisdiction.

C. All load ratings and safety factors shall meet or exceed those specified by all governing agencies with jurisdiction and shall be certified by a professional engineer.

D. Lift shall be subject to applicable state, local and city approval prior to installation and subject to inspection after installation. Determination of and adherence to these regulations is the responsibility of the lift contractor.

E. Welders certified in accordance with requirements of AWS D1.1 shall perform all welding of all parts.

F. Substitutions: No substitutions permitted.

1.05 WARRANTY

A. Manufacturer shall warrant the Porch-Lift® vertical platform lift's drive system for a period of two years after installation and all other components for one year after installation.

B. Extended Warranty (optional): Manufacturer shall warrant the Porch-Lift® vertical platform lift for a period of (specify:) 3 or 5 years after installation with the purchase of a preventative maintenance program from lift contractor for an equal number of years.

1.06 MAINTENANCE

A. The Porch-Lift® vertical platform lift must be maintained in accordance with manufacturer's instructions.

PART 2 PRODUCT

2.01 MANUFACTURER

A. Provide Porch-Lift® vertical platform lift model PL-S manufactured by ThyssenKrupp Access.

1. Contact: 4001 E. 138th Street, Grandview, MO; Telephone: 800-925-3100; Fax: 816-763-4467; Email: archassist@accessind.

com; Web site: www.tkaccess.com

2.02 MATERIAL

- A. Machine Tower: 14 ga. steel sheet.
- B. Guide Rail: 3" x 2" x 1/8" ASTM A500 grade B steel tubing.
- C. Base Frame: 2" x 2" x 1/4" structural steel tubing and angle.
- D. Lift Weldment: 3/8" hot rolled steel plate and 2" x 2" x 1/4" wall structural steel tubing.
- E. Side Guard Panels: 18 ga. galvanealed steel sheet in 1" x 2" x 14 ga. steel tubing frame.
- F. Front Access Panel: 20 ga. galvanealed steel sheet.
- G. Platform: 11 ga. steel plate.
- H. Access Ramp: 11 ga. steel plate.

2.03 FINISHES

- A. Components shall be prepared with 1)alkaline detergent wash, 2)clear water rinse, 3)iron phosphate coating, 4)clear water rinse and finished with electrostatically applied and baked thermostatic powder coat finish for indoor or outdoor use. Standard color is ivory.

2.04 ELECTRICAL SYSTEMS

- A. The electrical contractors shall provide a 115V, single phase, 20 amp, 60 Hz electrical power source connection.
- B. Electrical piping and wiring supplied by others.
- C. Final electrical connections performed by lift contractor.

PART 3 EXECUTION

3.01 ACCEPTABLE INSTALLERS

- A. Installers shall be experienced in performing work of this section who have specialized in work comparable to that required for this project.
- B. Installers shall be certified and trained by the manufacturer.

3.02 EXAMINATION

- A. Use field dimensions and approved manufacturer's shop drawings to examine substrates, supports and other conditions under which this work is to be performed. Do not proceed with work until unsatisfactory conditions are corrected.

3.03 INSTALLATION

- A. The Porch-Lift® vertical platform lift shall be installed in accordance with manufacturer's instructions and as specified and approved by architect.
- B. Landing gates and doors shall be installed by others. Electrical piping and wiring by others. Final electrical connections and lift adjustments by lift contractor.

3.04 DEMONSTRATION

- A. The lift contractor shall make a final check of the lift's operation with the Owner or Owner's representative present prior to turning the lift over for use. The lift contractor shall determine that operating and safety devices are functioning properly.

END OF SECTION

Notes: Go to www.tkaccess.com to download this specification in CSI format.

Intent of specification is to broadly outline equipment required but does not cover details of design and construction.

Dimensions and specifications are subject to constant change and continually evolving codes and product applications. For additional technical information, contact ThyssenKrupp Access at 800-925-3100 or www.tkaccess.com.

ThyssenKrupp Access
4001 East 138th Street
Grandview, MO 64030-2837
Phone: 816-763-3100
Fax: 816-763-4467
Sales: 800-669-9047
www.tkaccess.com